

PESO CESTELLO IN FERRO 41Kg  
 PESO CESTELLO IN VETRORESINA 48Kg  
 WEIGHT OF TUBULAR BASKET 41Kg.  
 WEIGHT OF FIBERGLASS BASKET 48Kg.

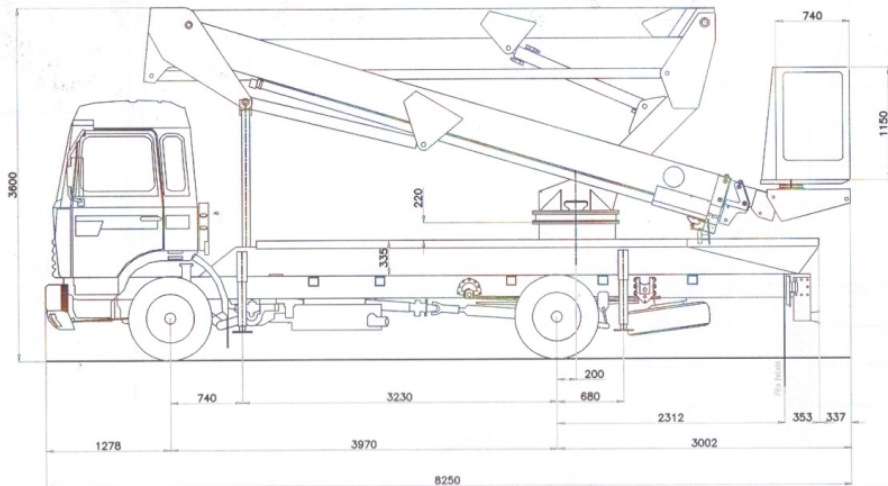
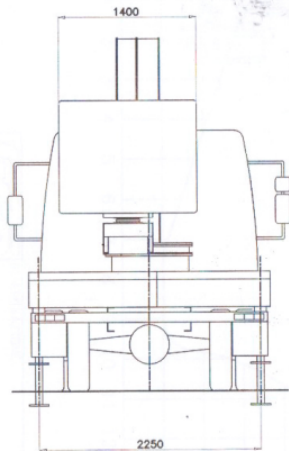

- x ATTENZIONE: LARGHEZZA MINIMA CONTRO IL RIBALTAMENTO
- x ATTENTION: MINIMUM WIDTH AGAINST OVERTURNING
- x ACHTUNG: MINDESTBREITE ZUR VERHEIDUNG VON UNKIPPEN
- x ATTENTION: LARGEUR MINIMUM CONTRE LE RENVERSEMENT
- x ATENCION: ANCHURA MINIMA PARA EVITAR EL VUELCO

**GSR**

269P - RENAULT M180.12/C

DATA	17-09-97
CODICE	438.160